



## VARIMETER

Residual current monitor (RCM)  
Insulation monitoring device (IMD)  
Insulation fault detection system (EDS)

# Residual current and insulation monitoring

## VARIMETER

### Does constant availability go without saying?

You know the situation: complex production systems, high requirements in terms of the quality, delivery time and reliability, permanent cost pressure. This requires more than ever a comprehensive operational readiness in order to be able to maintain and improve the competitiveness at the international level.

In practice, however, a comprehensive operational readiness is often given only conditionally, because insulation faults may slowly but progressively occur due to ageing, moisture, pollution, mechanical damage and other factors. Consequences of such undiscovered errors are costly plant shut-downs and operational downtime, repair costs and usually high costs resulting from production downtime. In the worst case these insulation faults are even a frequent cause of fires and personal injuries.

### The solution is simple:

Protection of people and machines by insulation monitoring and timely information about emerging critical operating conditions. DOLD Insulation and residual current monitoring systems have been successfully used for many years in most various areas.

### Automate the preventive maintenance.

In other words, we provide monitoring devices that alert already in the development stage of even the smallest insulation fault. In this way the fault can be removed in due time - before it comes to a standstill of your plant or the people working are exposed to a danger.

#### Various system architectures, various functioning principles:

System architecture:	earthed systems TN /TT system (TN-S system)	non-earthed systems IT systems
System type:	AC, DC, combined systems	AC, DC, three-phase current and combined systems
Measurement principle:	Measurement of the residual current using residual current transformer. All monitored conductors (except for the protective conductor) go through one residual current transformer.	Measurement of the insulation resistance against the ground.
Main reasons for monitoring:	Prevention of damages to the systems and system downtime, data losses, personal and fire protection	Prevention of damages to the systems and system downtime, data losses, personal and fire protection
Solution:	Residual current monitoring with the aid of VARIMETER RCM	Insulation monitoring with the aid of VARIMETER IMD and VARIMETER EDS
Field of application:	<ul style="list-style-type: none"> <li>Data centres, EDP devices and systems</li> <li>Office and administrative areas</li> <li>Power supply and distribution centres</li> <li>Communication systems</li> <li>Transportation technology (airports, ships, railway, ...)</li> <li>Production processes (with controlled drives)</li> <li>Machines and plants</li> <li>Frequency inverters</li> <li>UPS systems</li> <li>Battery installations</li> <li>Power plants</li> </ul> <p>... and many other fields and areas</p>	<ul style="list-style-type: none"> <li>Mobile power generator</li> <li>Areas used for medical purposes</li> <li>Transportation technology (railway, airports, ships, ...)</li> <li>Control circuits (robots, ...)</li> <li>Main circuits (controlled drives)</li> <li>Transportation systems with hoisting devices</li> <li>Power supply (battery networks, ...)</li> <li>Disconnected consumers (pumps, ...)</li> <li>Emergency lighting</li> <li>Power plants</li> <li>Solar plants</li> </ul> <p>... and many other fields and areas</p>
Standards:	<ul style="list-style-type: none"> <li>DIN VDE 0100-410: Low-voltage electrical installations, Part 4-41: Protective measures - Protection against electric shock</li> <li>DIN VDE 0100-551: Low-voltage electrical installations Part 5-55: Selection and erection of electrical equipment - Other equipment - Clause 551: Low-voltage generating sets</li> <li>DIN VDE 0100-710: Low-voltage electrical installations, Part 7-710: Requirements for industrial premises, areas and systems of special type - areas used for medical purposes</li> <li>DIN EN 61557-8: Electric safety in low-voltage networks up to AC 1000 V and DV 1500 V - Devices for checking, measuring or monitoring the protective measures - Part 8: Insulation monitoring devices for IT systems</li> <li>DIN EN 61557-9: Electric safety in low-voltage networks up to AC 1000 V and DV 1500 V - Devices for checking, measuring or monitoring the protective measures - Part 9: Installations for insulation fault detection in IT systems</li> <li>DIN EN 62020: Electric insulation material - Devices for monitoring the residual current for indoor installations and similar applications (RCMs)</li> </ul>	

# Maximum availability, for more efficiency

#### Advantages for you at a glance:

- ▶ Better operational and industrial safety: Preventive maintenance for protection of people and machines from dangers associated with electric current. No operational downtime in case of a single-pole short-circuit to the ground.
- ▶ Better fire safety: Timely detection of sneaky insulation faults. Minimisation of faulty electric arcs which represent a frequent cause of fires.
- ▶ Better accident safety: No malfunctions of machines and systems caused by short-circuits to the ground.
- ▶ High efficiency: Prevention of costly plant shut-downs, production downtime or data loss thanks to timely notification. Reduction of costs associated with maintenance, repair and re-commissioning.
- ▶ Optimised maintenance: Instant error localisation and information forwarding by centralised or decentralised alarm indication.
- ▶ Everything from a single source: In addition to variety of measurement and monitoring devices with standard function, we also offer you our long-standing experience in the development of individual, efficient problem solutions. Everything for protection of humans and machines.

And what can we do for you?

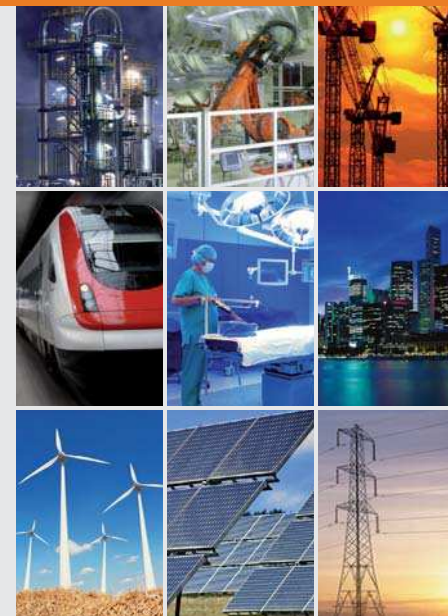

#### Custom-made solutions for monitoring

Starting from economical standard devices for monitoring individual parameters with multi-functional devices all the way to flexible, expandable fault reporting systems. DOLD offers a custom-made solution for protection of your machines and systems.



Residual current monitor (type A) IL 5882      Residual current monitor (type B) RN 5883

Insulation monitors MK 5880N

Insulation monitors LK 5896

# Residual current monitoring VARIMETER RCM

## Applications

Residual current monitoring device, also known as RCM (**R**esidual **C**urrent **M**onitor), measures and monitors the residual and fault currents in earthed systems (TN, TT systems). They are used in systems in which a message should be sent in event of an error, but the system should not be switched off. Disturbances resulting from insulation faults will therefore not lead to any unwanted operational downtime, damage to components and higher costs.

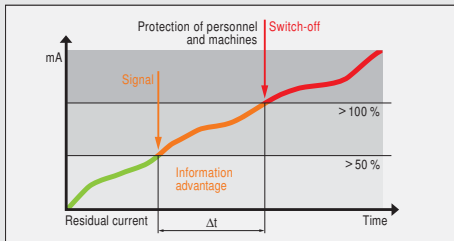

Information advantage obtained thanks to residual current monitoring

Difference to the residual current circuit breaker:

Residual current circuit breaker, so-called RCD (**R**esidual **C**urrent **P**rotective **D**evice), always leads to an immediate switch-off. The costly shut-down of the system or data losses can result from this.

On the other hand, residual current monitoring devices can display the existing residual current and indicate a case of exceeding the response value and/or switch off as well if required. The system operator in this way receives the information about the existing critical operating conditions early enough and in this way is able to prevent potential personal and component damages or fires.

The residual current monitoring device of the VARIMETER RCM family, with external or even integrated residual current transformer, will permanently monitor your system and check it for residual currents. Prevention of insulation disturbances will be indicated early enough for the measures of preventive maintenance and repair to be implemented successfully.

# for earthed systems

## Functioning principle of a residual current monitor (RCM)

All lines of the outflow which is to be protected (except for the protection line) will go through the residual current transformer. The sum of all currents equals zero in error-free mains; no voltage will be induced in the transformer. If a residual current flows via the ground, the difference in the current will be caused in the transformer. It will be recorded and evaluated by the electronic system of the residual current monitoring device.

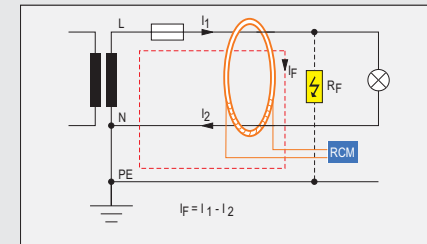

Functioning principle of a residual current monitor



The measurement process is applied to residual current monitoring devices which are used with pure AC currents and pulsating DC currents (type A according to IEC/TR 60755). All residual current monitoring devices sensitive to universal current (type B) require implementation of a special measurement process. They are suitable for measurement of all residual current types in electrical systems: AC currents, pulsating and even DC residual currents.

### Advantages

- ▶ Simple operation
- ▶ Tripping values can be adjusted via a potentiometer
- ▶ Wire break detection
- ▶ External or integrated residual current transformer
- ▶ Standard or sensitive to universal current
- ▶ Customer-specific versions

And what can we do for you?

## Overview of the residual current monitor: Use in earthed systems (TN, TT systems)

			
Device type	IL 5882	IR 5882	RN 5883
Classification according to IEC/TR 60755	Type A (AC, DC pulsating)		Type B (AC, DC even and pulsating)
Residual operating current	adjustable: 10 mA ... 10 A or 10 mA ... 30 A		adjustable: 10 mA ... 3 A
Response delay	adjustable		
Auto / manual reset	can be selected via the control terminal		+
Switching element / relay	2 x 1 c/o contact (pre-warning / alarm)		2 x 1 c/o contact (pre-warning / alarm)
Analogous output	-		0-10 V (optional)
Auxiliary voltage	AC/DC 12 V, AC/DC 24 ... 230 V		AC/DC 24 ... 80 V, AC/DC 80 ... 230 V
Overall width	35 mm	105 mm	52,5 mm
Residual current transformer accessories	ND 5016, ND 5019	integrated (Ø 28 mm)	ND 5015, ND 5018

## Overview of the residual current transformer: Use in earthed systems (TN, TT systems)

		
Residual current transformer for device type ("top hat" rail and screw mounting)	IL 5882	RN 5883
Inner diameter:	ND 5016/024	ND 5015/024
	ND 5019/035	ND 5015/035
	ND 5019/070	ND 5015/070
	ND 5019/105	ND 5018/105
	-	ND 5018/140
	-	ND 5018/210

### More information

RN 5883

Start

www.dold.com

# Insulation monitoring VARIMETER IMD

# for non-earthed systems

## Applications

Insulation monitoring device (abbreviated: IMD), monitors the insulation resistance in non-earthed systems (IT systems). DIN VDE 0100-410 and DIN VDE 0100-710 standards mandate the use of an insulation monitoring device in non-earthed systems, in order to detect a first occurring fault between an active conductor and a component or against the ground. The IMD has to emit an optical and / or acoustic signal if a first fault occurs. Disturbances which are the result of insulation faults and costly operational downtimes, personal and other damage associated with them are prevented.

### Timely information:

In non-earthed power supply systems (IT systems), no active conductors are connected directly to the ground. In case of an insulation fault, only a small residual current can flow for that reason, caused by the system leakage capacitance. Devices protecting from over-current do not respond in this case and the voltage supply remains maintained. The working

process, such as an operation, for instance, can be completed. Permanent monitoring of the insulation resistance carried out by the IMD ensures timely receipt of information about potential hazards. Faults can be removed early enough.

The insulation monitoring device is connected between the active mains conductors and the ground. When the measurement process is active, it supplies the mains with a measuring

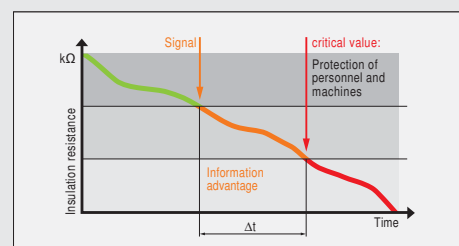

Information advantage obtained thanks to insulation monitoring

## Functional principle of the insulation monitoring device (IMD)

voltage. If an insulation fault occurs, the measuring circuit will close and a small current, proportional to the insulation fault will flow. This measuring current is evaluated by the electronic system of the device. If there are uncertainties in case of a certain insulation resistance (response value), a message will be sent via the device.

Insulation monitoring devices of the VARIMETER IMD family are available for both the DC and the AC voltage as well as for combined systems, such as for instance, systems with floating voltage and frequency, high system leakage capacitance or the DC component of the current.

Please contact us for further advice. We will be glad to help you.

### Advantages

- ▶ Simple operation
- ▶ Tripping values can be adjusted via a potentiometer
- ▶ For mains with up to AC 1000 V and DC 1000 V
- ▶ Monitoring of early warning alarm threshold value.
- ▶ For system leakage capacitance of up to 3000 μF
- ▶ Customer-specific versions

And what can we do for you?

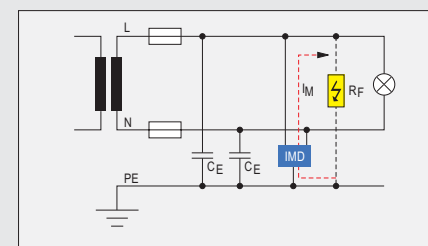

Principle in which the insulation monitoring device functions

## Overview of the insulation monitoring device: Use in non-earthed systems (TN, TT systems)

Device type	IL 5880 IP 5880	MK 5880N	MH 5880/500	RP 5888	IL 5880/200 IP 5880/200		IL 5881	IL 5881/100	RN 5897/300	RN 5897/010	UH 5892	LK 5894	LK 5895	LK 5896
Classification	Monitoring of three-phase current and combined systems					Monitoring consumer switched off	Monitoring of DC systems			Monitoring of mobile power generators	Monitoring of combined systems		... for higher system leakage capacitance e.g. solar systems	
IMD-Typ	AC						DC				AC/DC			
Nominal voltage of the IT system	AC 0 ... 500 V	AC 0 ... 500 V	AC 0 ... 500 V	AC 0 ... 500 V	AC 0 ... 500 V		DC 12 ... 280 V, DC 24 ... 500 V	DC 12 ... 280 V	DC 0 ... 300 V AC 0 ... 300 V	DC 0 ... 300 V (1000 V) AC 0 ... 250 V (760 V) (with coupling device)	DC 0 ... 600 V	DC 0 ... 690 V, AC 0 ... 690 V	DC 0 ... 1000 V AC 0 ... 1000 V	DC 0 ... 1000 V AC 0 ... 1000 V
Measuring frequency	10 ... 3000 Hz	10 ... 1000 Hz	10 ... 1000 Hz	10 ... 1000 Hz	10 ... 3000 Hz		-	-	DC or 40 ... 1000 Hz	DC or 16 ... 1000 Hz	DC or 40 ... 60 Hz	DC or 16 ... 1000 Hz		
Response value	5 ... 100 kΩ	5 ... 100 kΩ	5 kΩ ... 5 MΩ	5 kΩ ... 5 MΩ	5 kΩ ... 5 MΩ		5 ... 200 kΩ	5 ... 200 kΩ	10 kΩ ... 1 MΩ	1 kΩ ... 2 MΩ	fixed, within the range 10 ... 440 kΩ	1 kΩ ... 2 MΩ	1 kΩ ... 2 MΩ	1 kΩ ... 2 MΩ
Switching element / relay	1 x 2 Changeover contact	1 x 2 Changeover contact	2 x 1 Changeover contact	2 x 1 Changeover contact	2 x 1 Changeover contact		1 x 2 Changeover contact	1 x 2 Changeover contact	2 x 1 Changeover contact	2 x 1 Changeover contact	1 Changeover contact	2 x 1 Changeover contact	2 x 1 Changeover contact	3 x 1 Changeover contact
Analogous output	-	-	+	+	-		-	-	-	-	+	-	-	+
Auxiliary voltage	+	+	+	+	+		+	-	+	+	+	+	+	+
Overall width	IL: 35 mm IP: 70 mm	22.5 mm	45 mm	70 mm	IL: 35 mm IP: 70 mm		35 mm	35 mm	52.5 mm	52.5 mm	45 mm	90 mm	90 mm	90 mm
Accessories	RK 8832 <sup>1)</sup>	RK 8832 <sup>1)</sup>	RK 8832 <sup>1)</sup>	RK 8832 <sup>1)</sup>	RK 8832 <sup>1)</sup>		RK 8832 <sup>1)</sup>	RK 8832 <sup>1)</sup>	RK 8832 <sup>1)</sup>	RK 8832 <sup>1)</sup> , RP 5898 <sup>3)</sup>	RK 8832 <sup>1)</sup> , EH 5861/004 <sup>3)</sup>	RK 8832 <sup>1)</sup>	RK 8832 <sup>1)</sup>	RK 8832 <sup>1)</sup> , EH 5861/004 <sup>3)</sup>

<sup>1)</sup> Buzzer <sup>2)</sup> Indicating instrument <sup>3)</sup> Coupling device

# Insulation fault detection system VARIMETER EDS

## Applications

The reliability of the systems can be improved by using non-earthed power supply systems (IT systems), since the one-pole direct connection of the power supply to the ground remains maintained and the system can continue with its operation. Protective elements such as the line circuit breaker or fuses will respond only when a second error occurs. Immediate removal of the fault is in this case necessary. DIN VDE 0100-410 also recommends the first insulation fault in IT systems to be removed as soon as possible.

A device for insulation fault detection, also known as IFLS (Insulation Fault Location System), enables a fast localisation of insulation faults in a non-earthed power supply system. It is integrated within the insulation monitoring device and in case of a fault, it will supply a test current between the live line and the ground. The insulation fault will be localised with the aid of the residual current transformer in the consumer's outflow.

The insulation fault detection system of the VARIMETER EDS family (Earth-Fault Detection System), which consists of the test current transformer RR 5886 and the insulation fault detection device RR 5887, will automatically localise the fault source.

You will receive all necessary information about the faulty circuit and consumer's outflow during operation, which is of particularly great importance in widely diffused and complex systems. The maintenance and repair of your system can be planned as optimally as possible thanks to it. VARIMETER EDS is appropriate to use in most various areas.



Wide range of application

# for non-earthed systems

## Functioning principle of an insulation fault detection system (EDS)

The search procedure of the test current generator RR 5886 is normally activated by an insulation monitoring device when the response value is exceeded. The test current generator will then start supplying a test signal to the IT system. This limited test current will be evaluated in connection with the insulation fault detecting device RR 5887 and the residual current transformer connected to it, and the insulation fault will be in this way localised in the IT system. By connecting several insulation fault detection devices via one RS 485 bus connection, the number of measuring channels can be increased in increments of either 4 or 8 channels and the search for the insulation faults in widely diffused non-earthed power supply systems is refined in this way.

### Field of application



- ▶ Power plants
- ▶ Ship building industry
- ▶ Transportation technology
- ▶ Industrial systems
- ▶ Hospitals

Two different alarm levels, pre-warning and alarm, enable an early detection of faulty consumers. The insulation fault detection system of the VARIMETER EDS family can be operated more intuitively and simply thanks to automatic adjustment of the residual current transformer and clear design of adjusting and displaying units. The early detection and localisation of insulation faults enable their fast and target-oriented removal. As a user, you have many advantages from the operational safety and great availability of your IT system.

### Advantages

- ▶ Automatic and fast localisation of faulty circuits
- ▶ Increased reliability and availability of the system
- ▶ Optimal planning of maintenance and repair work
- ▶ No manual and time-consuming fault detection
- ▶ Simple operation
- ▶ Monitoring of complex systems

## Overview of the insulation fault detection system: Use in non-earthed systems (IT systems)

			
Device type	RR 5886	RR 5887	RR 5887/001
Classification	Test current generator	4-channel insulation fault detecting device	8-channel insulation fault detecting device
Nominal voltage of the IT system	DC, AC, 3 AC 24 ... 360 V	DC, AC, 3 AC 24 ... 360 V	DC, AC, 3 AC 24 ... 360 V
Fault memory	-	can be selected via the control terminal	
BUS interface	RS-485	RS-485	RS-485
Operating mode	Master / Slave	Slave	Slave
Auxiliary voltage	AC/DC 100 ... 230 V	AC/DC 100 ... 230 V	AC/DC 100 ... 230 V
Overall width	105 mm	105 mm	105 mm
Residual current transformer accessories	-	ND 5017	ND 5017

## Insulation fault detection - Block diagram

The example of the block diagram shows the basic structure of selective insulation monitoring using the test current generator RR 5886 and the insulation fault detection device RR 5887. As soon as an insulation monitoring device installed in an IT system, such as, for instance an LK 5895, reaches its response value, a test current generator will be activated by it and will automatically start the insulation fault detection process. The test signals generated are collected and evaluated by the connected residual current transformer ND 5017. Light emitting diodes which are allocated to the respective transformer, will enable simple localisation of a faulty consumer outflow. Due to the fact that the insulation monitoring device LK 5896 does not influence the insulation fault detection process, the test current generator will generate a switch-off signal at its terminals, for the measurement circuit of the insulation monitoring device.

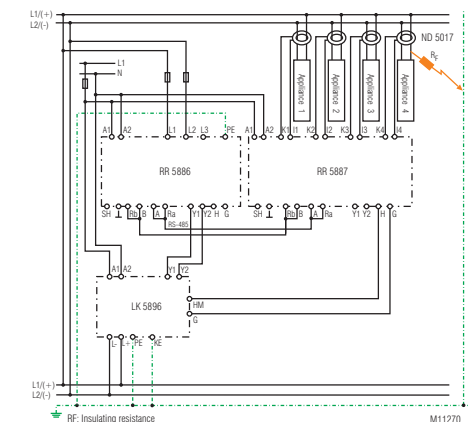

Block diagram of the insulation fault detection process

### More information

RR 5887

Start

www.dold.com

# Examples of application of the VARIMETER

## Example of application of residual current monitoring device IR 5882

The compact residual current monitoring device IR 5882 is suitable for use in the installation and industrial switchboards. The AC residual currents as well as pulsating DC residual currents will be recorded and evaluated with the aid of the integrated residual current transformer. Machines and systems are permanently monitored and checked for insulation faults. The residual current transformer IR 5882 will be additionally installed within the existing protective device and significantly increase the system availability and operational safety due to early detection of insulation faults.

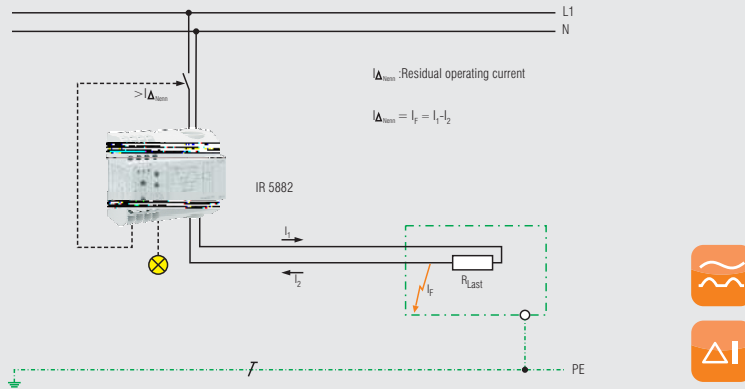

## Example of application of insulation monitoring device LK 5894

The insulation monitoring device LK 5894 is used by preference in industrial systems using the non-earthed DC / AC and combined systems. It is suitable for nominal voltages of up to 690V without a need for any additional ballast, and can also manage the system leakage capacitance of up to 1000  $\mu F$ . When a first insulation fault occurs, a warning will be issued, but nevertheless, the system can be normally operated afterwards. In order to prevent the industrial system to be switched off by fuses or protective devices in case a second insulation fault occurs, the first fault has to be removed as soon as possible.

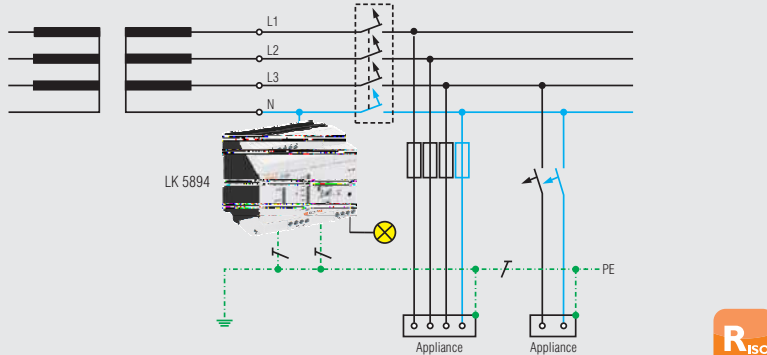

# Electrical safety at your disposal

## Example of application of insulation monitoring device LK 5896

The insulation monitoring device LK 5896 is optimally designed for monitoring of photo-voltaic systems thanks to its two measurement circuits, the main and the auxiliary measurement circuit. Whereas the DC component is monitored and checked for insulation fault by the main measurement circuit before the inverter, the auxiliary measurement circuit evaluates the insulation resistance against the ground on the AC side. And these all take place before the photo-voltaic system is switched on. In order to prevent two measurement circuits from influencing each other, the auxiliary measurement circuit will be deactivated via the control terminal when the system is switched on.

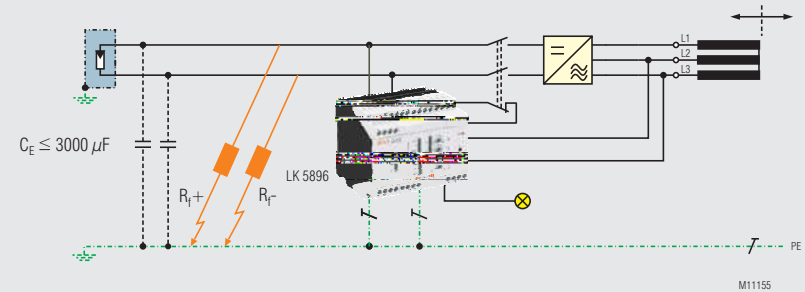

## Example of application of the insulation fault detection system RR 5886 / RR 5887

Devices for insulation fault detection can be easily used and are recommended in complex and widely diffused power supply systems. The insulation fault detection system is also advantageous for data centres, which are operated within a non-earthed system (IT system) for the reasons of availability and resistance to interference. The components the insulation of which has been damaged even earlier can be quickly localised and replaced even before their failure or burn-out which can sometimes be associated with data losses. Faulty circuits and consumer outflows are directly visualised on the insulation fault detection device RR 5887.

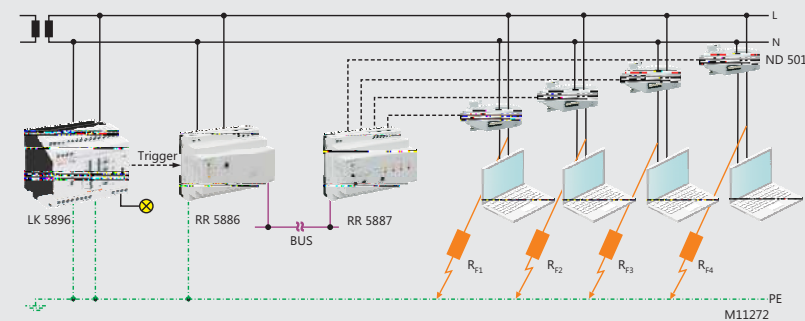

# Our experience. Your safety.

## VARIMETER - Monitor, measure, control

### Innovative monitoring solutions

DOLD offers a universal program of measuring and monitoring solutions which have been successfully in use worldwide for several decades already. DOLD develops tailored products for protection of your machines and systems, in addition to mono-functional standard devices for monitoring individual measurement variables and multi-functional solutions.

We will be happy to inform you about other monitoring solutions.

Please contact us for further advice.



### VARIMETER PRO

Universal measurement relays MK 9300N / MH 9300 of the VARIMETER PRO series can monitor up to 9 different parameters at a time. Quite simply and without any extensive wiring.



### VARIMETER EX

Thermistor engine-protective relays MK 9163N ATEX and MK 9003 ATEX of the VARIMETER EX series reliably prevent thermal overload of the engine. The devices monitor and protect the standard engines equipped with with PTC thermistors and explosion-protected engines in accordance with the standard 94/9/EC.



### VARIMETER NA

DOLD offers a safe and standard-compliant solution for optimal mains monitoring of photo-voltaic systems, wind turbine, hydroelectric power plant and combined heat and power units with their new voltage and frequency monitoring device RP 9811 of the VARIMETER NA family.



### VARIMETER

The space-saving phase monitoring device RK 9872 from the VARIMETER family monitors the under-voltage as well as over-voltage, and the phase sequence in the three-phase mains at the same time. For instance, in all applications of AC engines and machines.



# DOLD



**E. DOLD & SÖHNE KG**

P.O. Box 1251 • 78114 Furtwangen • Germany

Tel: +49 7723 6540 • Fax +49 7723 654356

dold-relays@dold.com • www.dold.com